

A Robust Overlapped-SCM WDM PON with a Standalone Burst-Mode OLT Receiver

Ziad A. El-Sahn, Bhavin J. Shastri, Jonathan M. Buset, and David V. Plant
 Photonics Systems Group, ECE Dept., McGill University, Montreal, QC H3A 2A7, Canada.

Abstract— We demonstrate an overlapped-SCM WDM PON using a burst-mode receiver capable of tracking instantaneous phase variations within the uplink. The receiver ensures proper alignment between the clock and up-converted data for efficient SCM down-conversion.

I. INTRODUCTION

Subcarrier-multiplexing (SCM) has been widely proposed for single-feeder wavelength-division multiplexed (WDM) passive optical network (PON) architectures [1]. Among the other techniques used to mitigate Rayleigh backscattering effect [2], SCM is preferred due to its simplicity and low cost. However, when used with reflective semiconductor optical amplifier (RSOA) optical network units (ONUs), symmetrical gigabit per second bit rates are difficult to achieve because of the bandwidth limitations of the RSOA. In other words, the subcarrier frequency and the bit rates are carefully chosen to separate the uplink and downlink enough and to accommodate them within the modulation bandwidth of the RSOA [3].

Recently, we have proposed an overlapped-SCM (O-SCM) technique that allows a certain overlap between uplink and downlink, to maximize the spectrum usage of the RSOA [4]. A global clock was used to provide perfect synchronization between both optical line terminal (OLT) and ONU for proper SCM operation. However, in a real system a clock and data recovery (CDR) unit is needed at the OLT. Furthermore, a phase aligner may be needed to support bursty uplink traffic and/or to correct for any phase shifts due to inherent signal jitter or other timing impairments.

In this work, we demonstrate a symmetric 2.5 Gb/s O-SCM WDM PON using a burst-mode (BM) CDR at the OLT that can capture instantaneous phase variations within the uplink for a robust SCM operation. We use a recently developed BM receiver based on space sampling with inexpensive electronics operated at the bit rate [5]. However, for SCM applications the recovered clock is at a higher frequency, therefore a clock divider is needed before down-conversion. For a proof-of-concept SCM burst-mode operation, we had to modify the design of that receiver to perform perfect alignment between the recovered frequency divided clock and the uplink data for efficient O-SCM down-conversion. We also propose a general SCM burst-mode CDR by replacing the Alexander *bang-bang* phase detector with a linear Hogue phase detector.

II. WDM PON WITH OVERLAPPED-SCM

Fig.1(a) shows the architecture of our overlapped-SCM WDM PON using an electro-absorption modulated laser

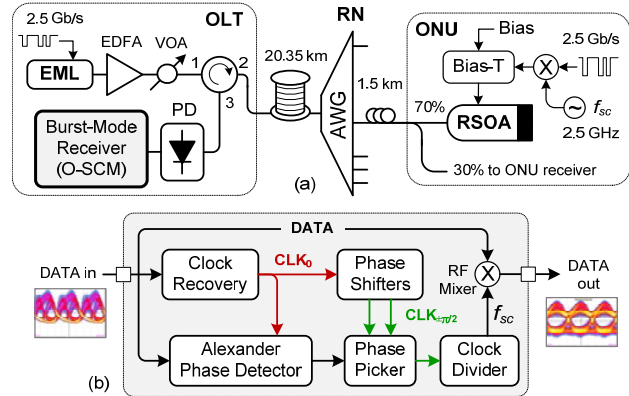

Fig. 1: (a) Proposed WDM PON architecture with overlapped-SCM (AWG: arrayed waveguide grating, EDFA: erbium-doped fiber amplifier, f_{sc} : subcarrier frequency, PD: photodiode, RN: remote node, VOA: variable optical attenuator), (b) proof-of-concept burst-mode receiver for SCM applications using a *bang-bang* Alexander phase detector.

(EML) at the OLT and a 2 GHz bandwidth-limited RSOA at the ONU side. The downlink is sent at 2.5 Gb/s over baseband with 2.43 dB extinction ratio (ER), whereas the uplink is sent at 2.5 Gb/s over a 2.5 GHz electrical RF subcarrier with a higher ER to trade-off downlink performance versus uplink efficient data remodulation. At the ONU, 70% of the downlink power is used to saturate the RSOA for proper downlink erasure, whereas the remaining 30% of power is passed to the downlink receiver. That coupling ratio was already optimized in [4] to guarantee error-free operation for both uplink and downlink with minimum OLT launch power. Different lengths of non-return-to-zero (NRZ) pseudo-random binary sequences (PRBS) are used for downlink and uplink similar to [4]. An EDFA and a VOA are used at the OLT to vary the OLT launch power (measured at the circulator output port '2') for the purpose of measurements. The proposed BM receiver is used at the OLT for clock and data recovery, instantaneous phase acquisition and efficient SCM down-conversion. In that experiment we test the receiver by applying phase steps within the uplink data but without introducing silence periods. The situation emulates phase instabilities that may be caused by inexpensive ONU parts and the bursty nature of the uplink.

III. SCM BURST-MODE RECEIVER DESIGN

The architecture of the proposed proof-of-concept SCM burst-mode receiver is shown in Fig. 1(b). A clock recovery unit is used to extract a 5 GHz clock (CLK_0) from the 2.5 Gb/s O-SCM uplink received signal. The clock signal is then sent to

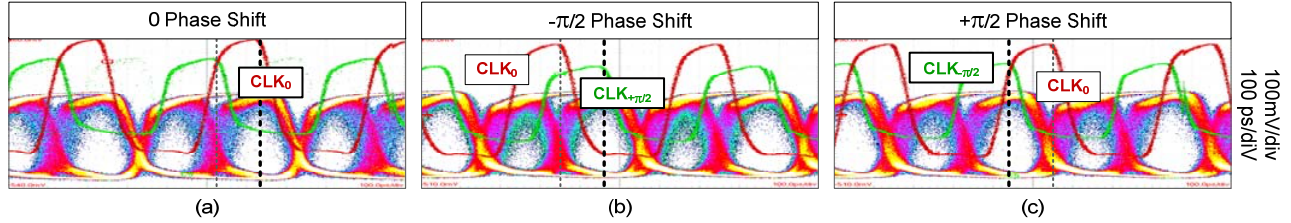

Fig. 3: Electrical eye diagrams before down-conversion for different phase shifts: (a) 0 phase shift, (b) $-\pi/2$ phase shift, and (c) $+\pi/2$ phase shift.

some phase shifters to generate phase shifted replicas of CLK_0 that are passed to a phase picker circuit; in that example $\pm\pi/2$ phase shifted clocks, namely $CLK_{\pm\pi/2}$. At the same time, a *bang-bang* Alexander phase detector compares CLK_0 with the incoming data to indicate whether it is leading or lagging, to control the phase picker to select the proper clock which is in phase with the uplink data. A clock frequency divider (in that case to go from 5 GHz to 2.5 GHz) then drives the RF mixer for SCM down-conversion. Because we are using here a 2-state phase detector, our proof-of-concept receiver will only be able to operate at two different states (in that case $\pm\pi/2$ phase shift). For experimental convenience, a phase shifted version of CLK_0 divided by 2 is used when no phase shifts are introduced. At the receiver output, a 1.875 GHz lowpass filter is used to remove out-of-band noise.

Fig. 2 shows the electrical eye diagrams of the received uplink signal (measured at the receiver input) for 0 and $\pm\pi/2$ phase shifts. The optimum sampling instants are marked with the dotted black line in the middle of the eye. The 2.5 GHz versions of CLK_0 and $CLK_{\pm\pi/2}$ to be used for down conversion are also shown. It can be seen that CLK_0 is only valid for the case of 0 phase shift, whereas for the cases of $\pm\pi/2$ phase shifts the receiver has the ability to select between $CLK_{+\pi/2}$ and $CLK_{-\pi/2}$ for an efficient SCM down-conversion.

To make the receiver able to instantaneously track phase variations over a full 0 to $\pm\pi$ range, we propose replacing the Alexander phase detector with a linear Hogge phase detector [6]. In that case, the output of the phase detector would simply control a phase shifter that adjusts the phase of CLK_0 before being passed to the clock divider and the RF mixer.

IV. EXPERIMENTAL DEMONSTRATION AND RESULTS

The performance of our overlapped-SCM WDM PON with the proposed SCM burst-mode proof-of-concept receiver is shown in Fig. 3. A 20.35 km feeder and 1.5 km distribution drop fiber all in standard single-mode fiber (SMF-28e+) are used at the optical distribution network (ODN) with a 100 GHz AWG at the remote node.

Fig. 3 shows the Q factor versus the OLT launch power for the different phase shifts presented in Fig. 2. When no phase steps introduced to the upstream, simply CLK_0 is used and the best Q factor can be achieved. As expected, the Q factor increases with the launch power. We have measured a Q factor of 14.25 dB at 6.65 dBm of launch power and corresponding to a bit-error-rate (BER) of 10^{-10} . At around 9 dBm of power we achieved also error-free transmission for the downlink. Now when we have a $\pm\pi/2$ phase shift within the uplink, we

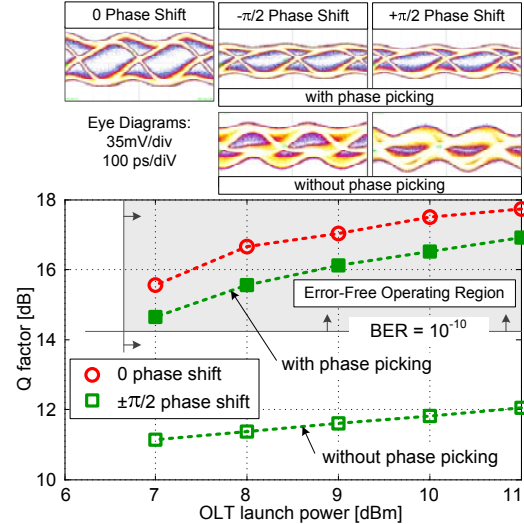

Fig. 2: Q factor versus OLT launch power for different phase shifts between the upstream data and the recovered clock.

can still achieve error-free operation when the correct clock is picked with the proposed receiver. On the other hand the performance is significantly degraded when the wrong clock (CLK_0) is used, *i.e.*, without phase picking. Our receiver provides more than 4 dB improvement in Q factor and guarantees error-free-operation due to its instantaneous phase picking. Eye diagrams shown as insets confirm our Q factor measurements and the proof-of-concept operation.

V. CONCLUSION

We demonstrated for the first time to our knowledge uplink burst-mode operation of a 2.5 Gb/s symmetrical WDM PON with overlapped-SCM. A proof-of-concept BM receiver based on a *bang-bang* Alexander phase detector was used to test the principle for $\pm\pi/2$ phase steps within the uplink. We showed that the receiver is able to track the instantaneous phase variations and to achieve efficient SCM down-conversion. We also suggested guidelines for a practical receiver using a variant design with a linear Hogge phase detector.

REFERENCES

- [1] Z. Xu, et al., J. Lightwave Technol., 27, 2069 (2009).
- [2] C. Arellano, et al., J. Lightwave Technol., 27, 12 (2008).
- [3] C. Arellano, et al., Proc. OFC'06, OTuC1 (2006).
- [4] Z. A. El-Sahn et al., Proc. OFC'11, OMP7 (2011).
- [5] B. J. Shastri et al., J. Sel. Topics Quantum Electron., 16, 1298 (2010).
- [6] C. R. Hogge, et al, Trans. on Electron. Devices, 32, 2704 (1985).